VH-1890 Vertical Machining Center

EQUIPMENT DETAILS



1. General introduction

VH-1890 CNC vertical machining center is a kind of processing equipment with excellent performance, wide range of processing technology, high precision and high production efficiency designed and manufactured by our company by adopting modern advanced mechanical, electrical, hydraulic and other new technologies. The machine tool adopts the OIMF numerical control system of Japan FANUC, which is currently the world's most advanced level , and can realize any 5- axis 4- linkage processing function .

This product has a wide range of applications and strong processing capabilities; it is mainly suitable for aerospace, shipbuilding, power generation, military industry, heavy machinery, locomotives, machine tools, textile machinery, printing machinery, mold manufacturing and other industries. The machine tool has the functions of drilling, boring, milling, expanding, reaming, tapping, linear interpolation, circular interpolation, nano interpolation, and three-coordinate linkage. It mainly performs CNC machining on various basic large parts, plate parts, disc parts, shell parts, molds and other various precision parts. It has the characteristics of high precision, high speed, high flexibility and environmental protection. Its performance indicators and precision indicators fully comply with national standards. After modular design, the products can be serialized and customized according to market demand. Its good performance-price ratio is the best choice for domestic and foreign customers.

The design of the machine tool conforms to the ISO international standard, and the measurement units of all parts, components and various instruments adopt the International System of Units (SI) standard.

2. General layout of the machine tool

The machine tool is to absorb foreign advanced technology design of C Type structure, and is mainly composed of a spindle box, a spindle component, a bed, a column, a saddle, a workbench, an electric cabinet, and an operating button station . The table moves horizontally along the saddle guide rail (X axis), the slide saddle moves longitudinally along the bed guide rail (Y axis), the column is fixed on the bed, the front of the headstock is hung

on the column, and moves vertically along the column guide rail (Z axis). The balance of the headstock is done with double pneumatic cylinders .

The three linear motion axes of the machine tool are:

- (1) Moves laterally along the saddle (X axis)
- (2) The saddle moves longitudinally along the bed (Y axis)
- (3) The headstock moves vertically along the column (Z axis)

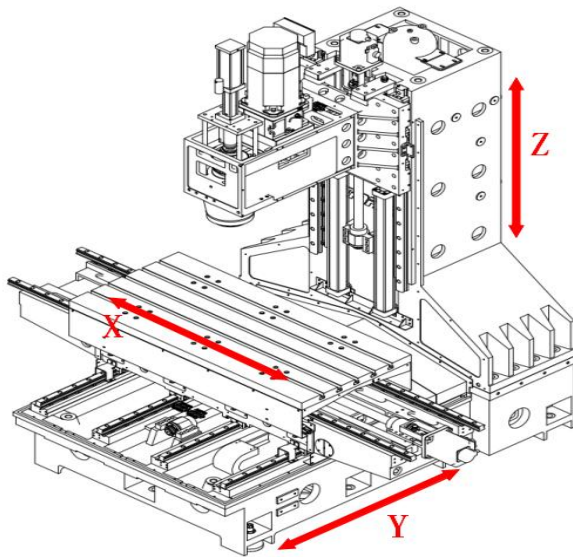

3. The main technical parameters of the machine tool

Name	Item	Unit	Specification
Workbench	Size (W X L)	mm	2000×900
	T-slot (size x qty x spacing)	mm	22×5×150
	Max. Load	kg	2200
Travel	X axis	mm	1800
	Y axis	mm	1000
	Z axis	mm	800
	Spindle nose to worktable surface distance	mm	200~1000
	Distance from spindle center to Z- axis rail surface	mm	985
Fast speed	X axis	mm/min	20000

	Y/Z axis			20000
Feed rate	X/Y axis		mm/min	10000
	Z axis			10000
Spindle	Spindle rated power		KW	15/18.5
	Spindle torque		Nm	186/300
	Spindle speed		rpm	40-6000
	Spindle taper			BT 50
Precision	Positioning precision	x	mm	0.015 (Full length)
		y	mm	0.010 (Full length)
		z	mm	0.010 (Full length)
	Repeatability	X/Y/Z	mm	0.012/0.008/0.008
	Machine tool inspection precision standard		GB/T 20957.4-2007	
Other	Total capacity of machine power supply		KVA	45
	Barometric pressure		bar	6.5
	Machine weight (approx.)		T	15
	Machine dimensions (L X W X H)		mm	5925*4070*3660

4. Common accessories for machine tools

NO.	Item	Manufacturer	Origin	Specification
1	Control System	FANUC	Japan	OIMF
2	Spindle motor	FANUC	Japan	15/ 18.5KW
3	Three-axis motor	FANUC	Japan	X/Y/Z:3/3/3KW
4	Spindle	Jirfine	China	BT50 6000 RPM
5	Three-axis ball screw	THK /HIWIN/PMI	Japan / Taiwan	X 50 / 10 : Y 50 / 10 : Z 50 /10
6	Guideway	THK /HIWIN/PMI	Japan / Taiwan	X/Y /Z : 2 × 55 / 4 × 55 / 2 × 55 (roller type)
7	Bearing	KOYO/NACHI	Japan	40TAB72

8	Coupling	KTR / Julihe	Germany /China	X / Y / Z : 35*35
9	Unclamping tool system	Chen Sound	Taiwan	BPT-10U5S35L13M
10	The electromagnetic valve	SMC/CKD	Japan	SY5120
11	Spindle Cooling System	Rico /Tongfei	China	RC0-15PTS3
12	Cutting cooling motor	HZQC	China	4V-40 (1000W)
13	Three point combination air pressure Valve	SMC/CKD	Japan	AW30 +AFM30
14	Breaker	Schneider	France	NSC100B3100,3P-100A
15	Relay	Omron	Japan	MY2N-GS
16	Switching power supply	Omron	Japan	S8FS-C35024
17	Central lubrication system	BAOTN	China	BT—C2P4—226
18	Tool magazine	Jirfine	China	BT50- 24T

Note: The manufacturer reserves the right to change brands depending on reasons such as delivery period/technical improvement.

5. The main structural characteristics of the machine tool

5.1. Machine tool spindle

The main drive adopts the main shaft AC servo motor as the power source, which is transmitted to the main shaft group through the belt . The spindle group has high precision and high performance. The spindle group has constant temperature cooling, which automatically tracks and controls the temperature of circulating cooling oil to ensure that the temperature rise of the spindle does not exceed 45 °C during long-term high-speed rotation , which improves the stability of the spindle precision and the machining accuracy of the machine tool. The spindle box components are balanced by dual air cylinders The mechanism ensures the stability of the movement of the headstock.

5.2. Feed transmission of each axis

X-axis drive—the servo motor drives the ball screw through the coupling , which drives the table to move left and right on the saddle to realize the X-axis feed movement, and

pre-stretches the screw to increase the rigidity of the screw pair.

Y-axis drive—the servo motor drives the ball screw through the coupling to drive the saddle to move back and forth on the bed to realize the Y-axis feed movement.

Z-axis drive—the servo motor drives the ball screw through the coupling , and drives the spindle box to move up and down on the column to realize Z-axis feed. And the Z-axis motor has an automatic brake function. In the case of power failure, the automatic brake will hold the motor shaft tightly so that it cannot rotate. The shaft adopts dual air cylinder balance mechanism to ensure the stability of the headstock movement.

5.3. Basic parts

The bed, table, column and saddle of the machine tool are all made of high-quality cast iron (HT300), and have been subjected to multiple aging treatments. The overall structure design of the machine tool adopts FEM finite element analysis and optimization technology in order to obtain higher rigidity. The bed, saddle, and column of the machine tool are closed box-shaped structures, the reinforcing ribs are arranged reasonably, and multi-point support is adopted; the column is a super large herringbone structure, and the reinforcing ribs are arranged vertically and horizontally, which has sufficient bending resistance . , torsional strength and high rigidity of the basic parts, which can meet the requirements of heavy-duty cutting.

5.4. Machine tool guide rail

X-axis guide pair—Two heavy-duty ball- type linear guides are adopted, with small friction coefficient, high sensitivity of the workbench, small high-speed vibration, no crawling at low speed, high positioning accuracy, excellent servo drive performance; at the same time, large load-bearing capacity and cutting resistance Good vibration performance can improve the performance characteristics of the machine tool, improve the accuracy and precision stability of the machine tool and the service life of the machine tool.

Y-axis guide rail pair—it adopts four heavy-duty ball- type linear guide rails, which have sufficient bending rigidity and torsional rigidity.

Z-axis guide rail— two heavy-duty roller- type linear guide rails are used to ensure smooth cutting during processing.

5.5. Lubrication system of machine tool

The main control components of the lubrication system are all well-known domestic brands, which are balanced and reliable.

Machine tool lubrication form: automatic thin oil lubrication guide rail and screw rod .

5.6. Cooling system of the machine tool

The cooling system of the machine tool adopts an external cooling method, and its cooling liquid is an emulsified non-corrosive liquid.

5.7. Machine tool protection device

Y , Z axis of the bed guide rail adopts the anti-rust metal telescopic protective cover.

The outer protection of the fuselage adopts full airtight protection .

5.8. Perfect protection measures

NO.	Function
1	Spindle Drive Fault Protection
2	Spindle system overload protection
3	tool loading, unloading and spindle start
4	Three-axis soft limit protection
5	Gravity axis power down slide protection
6	Feed drive failure protection
7	Feed system overload protection

6. Machine tool electrical system

6.1. The machine tool adopts the M80A CNC system of Mitsubishi Corporation of Japan , equipped with a 10.4 " color liquid crystal display + MDI operation panel ; the front of the display has a CF card interface and a USB interface , and the back has an Ethernet interface for communication.

Control axis		
1	Number of mechanical groups	A group
2	Number of control paths (excluding workpiece loading and unloading control paths)	All the way
3	Simultaneously controlled axes expansion (each	Up to 4 axes

	path)	
4	PMC-based axis control	Cannot be Cs axis
5	Axis name	Choose from X, Y, Z, U, V, W, A, B, C
6	Extended axis name	Up to 3 characters
7	Indirect axis address command	Included in user macro program
8	Extended spindle name	Up to 3 characters, included in the multi-spindle
9	Feed axis synchronous control	Up to 4 groups
10	Torque control	Included in PMC axis control
11	Minimum setting unit	IS-A, IS-B
12	Minimum setting unit C	0.0001mm, 0.0001deg, 0.00001inch
13	High-precision program instructions	Included in the minimum setting unit A~E
14	Flexible feeding device	Any DMR
15	HRV3 control	Please use HRV3 control as much as possible to achieve machining
16	Imperial/Metric Conversion	
17	Interlock	All axes/every axis/axis direction/segment start/cutting segment start
18	Mechanical lock	All axes/every axis
19	Overtravel	
20	Stored stroke detection 1	
21	Travel limit external setting	
22	Stored stroke detection 2, 3	
23	Travel limit detection before moving	
24	Mirror image	Each axis
25	Location tracking	
26	Servo OFF/Robot Handwheel Feed	
27	Abnormal load detection	
28	Position switch	
29	Emergency stop	
Run operation		
1	Autorun (memory)	
2	MDI run	

3	DNC operation	Cable interface
4	DNC operation via memory card	Requires CF card and CF card adapter
5	Scheduling function	
6	Program number search	
7	Sequence number search	
8	Sequence number comparison and stop	
9	Program restart	
10	Fast program restart	
11	Rapid Program Restart/Restart Key Retention	Fast program restart is required
12	Prevention of wrong operation	
13	Rigid tapping retraction	
14	Buffer register	
15	Dry run	
16	Single block	
17	JOG feed	
18	Return to reference point manually	
19	Stopper-free reference point setting	
20	Mechanical bumper type reference point setting	
21	Reference point return speed setting	
22	Reference point offset	
23	Hand wheel feed 1	1/all paths
24	Hand wheel feed 2 or 3	2 or 3
25	Handwheel feed override	×1, ×10, ×m, ×n m: 0 to 2000, n: 0 to 2000 Included in handwheel feed
26	Handwheel feed interrupt	
27	Incremental feed	×1, ×10, ×100, ×1000, ×10000
28	JOGI, handwheel feed in the same mode	Included in handwheel feed
29	Handwheel feed back	The first handwheel feed is required
30	Operation of USB memory program (Load&Go function)	
Imputation function		
1	Nano imputation	

2	Position	G00 (linear interpolation type positioning is also possible)
3	One-way positioning	G60
4	Exact stop method	G61
5	Tapping method	G63
6	Cutting method	G64
7	Exact stop	G09
8	Linear interpolation	
9	Circular interpolation	
10	Pause	
11	Spiral interpolation	Circular interpolation + up to 2 axes linear interpolation
12	Jump over	G31
13	Multi-step skip	
14	High speed skip	The number of input points is 8 digits
15	Torque Limit Skip	
16	Return to reference point	G28
17	Return to reference point detection	G27
18	Return to the 2nd reference point	
19	Return to the 3rd and 4th reference points	
Program input		
1	Tape code	Automatic recognition of EIA/ISO
2	Mark skip	
3	Parity check	Horizontal and vertical parity
4	Control I/O	
5	Maximum command value	±9 digits (R, I, J, K are ±12 digits)
6	Program file name	32 characters
7	Sequence number	N8 digits
8	Absolute/incremental command	Can be mixed in the same paragraph
9	Decimal point entry/Calculator decimal point entry	
10	10 times input unit	
11	Diameter/radius designation	
12	Plane selection	G17, G18, G19

13	Rotation axis designation	
14	Flip of the axis of rotation	
15	Polar coordinate command	
16	Coordinate system setting	
17	Automatic coordinate system setting	
18	Workpiece coordinate system	G52~G59
19	Workpiece coordinate system preset	
20	Add the number of workpiece coordinate system groups	48 groups
21	The measured value of the workpiece origin offset value is directly input	Included in the workpiece coordinate system
22	Manual absolute value ON/OFF	
23	Arbitrary angle chamfering/corner R	
24	Programmable Data Input	G10
25	Programmable parameter input	
26	Subroutine call	10 levels of nesting
27	User macro	
28	Additional user macro public variables	#100~#199、#500~#999
29	Fixed cycle for drilling	
30	Arc radius R specified	R, I, J, K 12 digits
31	Automatic corner magnification	
32	Scaling	
33	Coordinate system rotation	
34	Programmable mirror	
35	Pre-read masking based on G-code	
36	Macro execution program	
37	Macro command execution program + C language execution program	
38	Custom software capacity (overall system capacity)	6MB
39	FANUC PICTURE execution program	More than 4M custom software capacity is required
40	Processing preparation support function	
Settings/Display		
1	Status Display	

2	Clock function	
3	Current location display	
4	Program comment display	Program name 31 characters
5	Parameter setting display	
6	Parameter checksum function	
7	Alarm display	
8	Alarm history display	
9	Operation information history display	Requires external information or external data input
10	Working time/number of parts display	
11	Actual speed display	
12	Actual number of spindle revolutions/T code display	M system requires thread cutting and synchronous feed
13	Floppy directory display	
14	Operation monitor screen	Display load gauge etc.
15	Servo adjustment screen	
16	Spindle adjustment screen	Included in spindle serial output
17	Servo waveform display	
18	Maintenance information screen	
19	Troubleshooting	
20	Efficient processing settings	
21	Surface fine setting	
22	Automatic adjustment function of gain and filter	
23	Software Operation Sketchpad	
24	Software operation sketchpad universal switch	A software operation panel is required
25	Software operation sketchpad universal switch extension	Included in the software operation panel universal switch
26	Operation history display	
27	Multilingual display	
28	Dynamically switch language display	Included in each language display
29	Data protection key	4 types
30	Clear screen	Manual or automatic
31	Parameter setting support screen	

32	Help function	
33	Self-diagnosis function	
34	Scheduled maintenance screen	
35	Hardware/software system configuration screen	
36	Servo information screen	
37	Spindle information screen	Included in spindle serial output
38	Graphic display	
39	Dynamic graphics display function	
40	CNC screen display	Requires CNC Application Development Kit (A08B-9010-J555#ZZ12)
41	Power Consumption Monitoring	
42	Main menu screen	
Communication function		
1	Embedded Ethernet	
2	Embedded Ethernet extension function	Included in Embedded Ethernet

6.2. Electric cabinet part

The safety protection level of the electric cabinet meets the IP54 standard, and the electric cabinet adopts a fully enclosed structure.

7. Accessories

NO.	Name	Models and Specifications	Qty	Manufacturer
1	Anchor screws	M36×2P×125×Ø17	1 set	China
2	Ground anchor bolts and nuts	M16×500L	1 set	China
3	Machine tool shim	Ø140×Ø22×60	1 set	China

4	Toolbox	Allen wrench 2.5-10 Slotted screwdriver Phillips screwdriver Open-end wrench 3 No. 2 plum Open-end wrench Air gun and spring duct Glass glue	1 set	China
5	Chip conveyor	Two snails and one chain + chip collector	1 set	China
6	Spindle oil cooler	Rico /Tongfei	1 set	China
7	CF card	2G	1PC	China
8	USB card reader		1 PC	China
9	Cable	5 meters	1 PC	China
10	Transformer	45KVA	1PC	China

8. The preparations before the installation of the machine tool that the user needs to carry out

Foundation preparation:

- According to the foundation drawing provided by the manufacturer, find a professional design institute to design the foundation construction drawing according to the actual situation of the user's soil.
- Make the foundation according to the professional foundation construction drawings, the foundation must be solid, rigid, smooth concrete foundation, and meet the requirements of the manufacturer's foundation drawings.
- The foundation is laid well, and the machine tool can only be installed after the concrete is completely solidified.

Incoming power supply preparation:

- 3-phase AC 380V \pm 10%, 50Hz \pm 2 % , the user provides the power line from the

power supply of the factory building to the machine tool electric cabinet and the ground wire from the electrical cabinet to a separate grounding point, and the ground wire part requires separate grounding.

Tool spreader preparation:

- Unpacking tools, lifting equipment and hoisting ropes

Gage preparation:

- Square ruler (L= 400), square ruler (L=1000), dial indicator, magnetic gauge base, square gauge (L≥315), contour block, inspection rod, etc.;

other:

- Grouting tools, foot bar bushings, etc.

9. Machine tool operating environment and testing requirements

9.1 Machine tool working environment

The working environment of the machine tool is directly related to the performance and normal operation of the machine tool. If the temperature is too high, the control mechanism in the numerical control system will fail or malfunction; if the temperature is too low, the working conditions of the lubrication system and hydraulic system will deteriorate and the machine tool Faulty or damaged machine parts. Therefore we recommend that the machine be used under the following conditions:

- The machine tool should be placed indoors and in a dry environment. The machine tool foundation is manufactured according to the requirements of the machine tool foundation.
- Power supply voltage: 3-phase AC 380V $\pm 10\%$, power frequency: 50Hz $\pm 2\%$. Beyond this range, the user needs to purchase a regulated power supply by himself.
- Ambient air temperature: within the range of -5°C to 40°C;
- Humidity: relative humidity not exceeding 75% , and changes in humidity do not cause condensation.
- The dust concentration in the air shall not exceed 10mg/m³, and shall not contain

acid, salt and corrosive gas.

- Atmospheric pressure 86~106kpa
- Machine tools should be installed away from vibration and heat sources. The power in the workshop where the machine tool is installed should be below 0.5G (G is the acceleration of gravity).

9.2 Inspection conditions of machine tool accuracy

In order to ensure that the machine tool operates with the specified accuracy, the user shall inspect according to the following requirements.

When inspecting the accuracy of the machine tool, the ambient temperature should be kept within the range of -5 to 40°C in accordance with:

Machine tools and gages should be placed in the testing environment for a sufficient period of time (preferably overnight) to ensure a thermally stable state prior to testing. Drafts and external radiation such as sunlight, external heat sources, etc. should be avoided.

The rate of change of the ambient temperature in °C/h during the 12 hours before the test and during the test should be within the range of the above requirements.

When continuously approaching any specific target position during detection, if the deviation forms an orderly sequence, it should be considered that the thermal state is still unstable, and these trends should be minimized by heating up the operation.